

The Chloride Conductance of Tight Junctions of Rat Ileum Can Be Increased by cAMP But Not by Carbachol

P.B. Bijlsma, R. Bakker, J.A. Groot

Graduate School for the Neurosciences, Institute of Neurobiology, Faculty of Biology, University of Amsterdam, Kruislaan 320, 1098 SM Amsterdam, The Netherlands

Received: 7 September 1996/Revised: 5 November 1996

Abstract. It is well known, that in mammalian small intestine, cAMP increases Cl^- permeability of the apical membrane of enterocytes as part of its secretory action. Paradoxically, this is usually accompanied by an increase of the transepithelial resistance. In the present study we report that in the presence of bumetanide (to block basolateral Cl^- uptake) cAMP always decreased the transepithelial resistance. We examined whether this decrease in resistance was due to a cAMP-dependent increase of the paracellular electrolyte permeability in addition to the increase of the Cl^- permeability of the apical cell membrane. We used diffusion potentials induced by serosal replacement of NaCl, and transepithelial current passage to evoke transport number effects. The results revealed that cAMP (but not carbachol) could increase the Cl^- permeability of the tight junctions in rat ileum. Moreover, we observed a variation in transepithelial resistance of individual tissue preparations, inversely related to the cation selectivity of the tissue, suggesting that Na^+ permeability of the tight junctions can vary between preparations.

Key words: Paracellular pathway — Sodium conductance — Transport number — Ion selectivity — Transepithelial resistance — Tetrodotoxin — Bumetanide

Introduction

Since the pioneering studies of Frömter [14] it is well known that in leaky epithelia the paracellular pathway can comprise more than 90% of the transepithelial con-

ductance. The paracellular pathway consists of a series array of the tight junctions and the lateral intercellular space. The tight junctions are considered to be the most important barrier in this array. It is evident, however, that the interspace becomes more important when its diameter decreases [14].

The epithelia of small intestine and gallbladder behave as cation selective barriers [6, 13]. This is because the paracellular pathway dominates the transepithelial permeability and the tight junctions have a larger conductance for cations. It has been reported that the cation selectivity of these epithelia can be decreased by cAMP-generating drugs [4, 11, 27]. This conclusion is primarily based on measurements of diffusion potentials induced by replacing part of the NaCl in the bathing solution at one side of the epithelium by an inert non-electrolyte. These so called dilution potentials are indicators for the ion selectivity of the epithelium and changes in these transepithelial potential differences reflect changes in ion selectivity of the paracellular pathway if the ion permeability of the cell membranes remains unaltered. The conclusion that the ion selectivity of tight junctions of *Necturus* gallbladder [11] can be modulated by cAMP must be questioned since (i) it is known now that in this tissue cAMP also induces an increase of the Cl^- conductance in the apical cell membranes [26], thereby reducing the cation selectivity of the tissue, (ii) cAMP induced a decrease of the transepithelial conductance in the gallbladder due to a collapse of the lateral intercellular space [19]. This makes this part of the paracellular pathway more important and because the transport numbers (t) in the lateral intercellular spaces are based on free solution mobility, with $t_{\text{Cl}} > t_{\text{Na}}$, the cation selectivity of the paracellular pathway should decrease. In contrast, in fish intestine, where cAMP has no effect on the ion permeability of the apical

membrane of the epithelial cells [4, 20, 28], it has been demonstrated that cAMP can increase the conductivity of the tight junctions for specifically some anions, including Cl^- [3, 5]. Although the details of the mechanism remain to be elucidated, it is evident that the anion conductance of the tight junctions is regulated by cAMP because it can be increased by the permeable form 8-Br-cAMP and by the adenylate cyclase activator forskolin and can be regulated by cAMP-related transmitters like VIP and epinephrine and the cAMP sparing inhibitors of phosphodiesterase [3, 4]. Cytoskeletal-active [21] agents induced a *nonselective* permeability increase [5].

The main goal of the present study was to answer the question whether, like in fish intestine, the Cl^- conductance of the tight junctions of rat ileum can be increased by cAMP. The absence of the cAMP-sensitive Cl^- channels in the apical membrane of fish enterocytes makes it possible to use cAMP mediated changes in dilution potentials as indicator for modulation of the ion selectivity of the tight junctions. In rat ileum, however, the mucosal dilution potential (serosa-negative potential change) is diminished and the serosal dilution potential (serosa-positive potential change) is increased by cAMP because of the activation of the transcellular Cl^- secretion which in itself causes a serosa positive potential change. Would it have been possible to block the apical cAMP-activated Cl^- channels in the rat ileum then one would have a tissue like fish intestine. However, we found none of the tested Cl^- channel blockers (DPC, 9AC, SITS, NPPB) effective in preventing the serosa positive potential change upon cAMP application in rat ileum (R.B. Bajnath, P.B. Bijlsma, J.A. Groot, *unpublished observations*). As an alternative we compared the effect of cAMP on the serosal dilution potential in the absence and presence of the NaK2Cl cotransport-inhibitor, bumetanide. Bumetanide causes a strong reduction of the forskolin-evoked potential change in rat ileum [16]. The Cl^- permeability at the basolateral side of the epithelial cells is not affected by forskolin [11] and, in the presence of a K^+ -channel blocker in the serosal bath, application of forskolin will not change the cellular component of the ion selectivity at the basolateral side.

Another test we used to determine the influence of forskolin, is the effect of current passage through the epithelium. This technique has previously been used to study the ion-selectivity of tight junctions in leaky epithelia, including fish intestine [5, 7, 14]. The background of this method is described in detail in the method section. Furthermore, we compared the effects of cAMP and forskolin to the effects of carbachol, another secretagogue, acting via a different pathway.

Materials and Methods

ELECTROPHYSIOLOGICAL MEASUREMENTS

Female Wistar rats (200–300 g) were anesthetized by intraperitoneal injection of sodium-pentobarbital (60 mg/kg). A midline abdominal

ventral incision was made, segments of distal ileum were ligated, incised next to the ligatures and rinsed with Ringer's solution to remove intestinal contents. After ligating the blood supply to the segment it was removed, stripped of muscle layers and flat sheets of tissue were mounted in tissue holders described elsewhere in detail [3]. The time between cutoff of blood supply and mounting of tissue holders in the Ussing chambers was less than 2 min. Two sheets of tissue were prepared simultaneously and were used as control and experimental tissue. The exposed area was 0.2 cm² and free of Peyer's patches. Both sides of the epithelium were perfused with Ringer's solution, gassed with humidified 5% CO_2 + 95% O_2 . Solutions were maintained at 37°C with water jackets and recirculated (total volume 3 ml on either side) with a roller pump. No hydrostatic pressure differences occurred during changes of the perfusion solutions. Transepithelial potential differences was measured using Ag-AgCl electrodes connected to the perfusion medium by Ringer-agar bridges. The tips were placed at less than 1 mm from the epithelium in the middle of the exposed area. The resistance was calculated from voltage deflections evoked by 1-sec bipolar current injections of +10 and -10 μA through platinum electrodes placed 2 cm from the epithelium and is given as ohm.cm². When serosa-to-mucosa or mucosa-to-serosa direct currents were passed, the output of a constant current source was connected to the current passing electrodes so that the effect of direct current on the transepithelial resistance could be followed continuously. The direct current was passed as long as necessary to reach a plateau value of potential and resistance. Corrections were made for the resistance of the perfusion solutions and, when necessary, for potential differences across the agar bridges which were calculated by the Henderson equation. The input resistance of the amplifiers was higher than 10⁹ ohm. The amplifiers were connected to recorders so that potential and resistance could be followed continuously.

FLUX MEASUREMENTS

Intestinal sheets, were mounted on tissue holders to separate two compartments filled with 3-ml Ringer's and stirred with magnetic buttons. A stream of humidified 95% O_2 and 5% CO_2 was passed over the solutions. Six intestinal sheets were used in one experiment. ³⁶Cl was added to either the mucosal or serosal compartment. At 30 min, by which time steady state fluxes had been achieved, three 0.1-ml samples were taken and this was repeated at 40 min. Dibutyl cyclic AMP (1 mM) was added thereafter to four serosal compartments and in two of these also 0.1-mM bumetanide. Further samples were taken at 50 and 60 min. The changes in the fluxes were calculated from the 10-min period before and after drug addition. Serosa-to-mucosa fluxes of ²²Na in the presence and absence of 8-Br-cAMP were monitored in separate experiments with bumetanide present throughout.

CALCULATIONS

The $g_{\text{Na},ij}$ and $g_{\text{Cl},ij}$, the conductance of the tight junctions for Na^+ and Cl^- respectively was calculated with the assumption that the paracellular conductance comprises 95% of the tissue conductance [24] and that the lateral intercellular space contributes 15% to the resistance, based on the mean decrease of the resistance due to mucosa to serosa current (this paper). This allows to calculate G_{ij} (conductance of tight junctions) which is considered to be the sum of $g_{\text{Na},ij}$ and $g_{\text{Cl},ij}$. The participation of K^+ has been left out because of its much lower concentration.

The change of the transepithelial potential (dE_{ij}) induced by mucosal dilution of NaCl was corrected for the tip potential, calculated from Henderson's equation, and used to calculate the transport number of Cl and Na, using the Hodgkin and Horowitz equation: $dE_{ij} =$

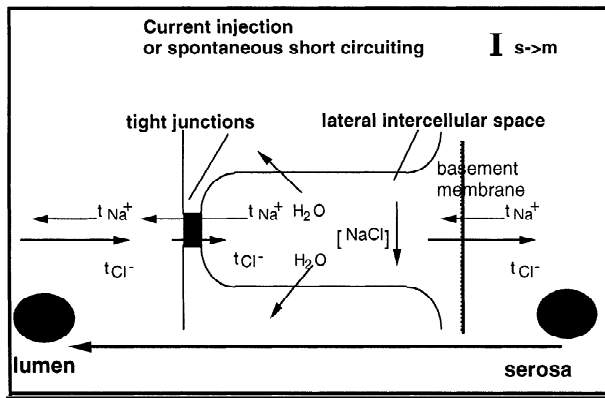

Fig. 1. Schematic representation of the effect of direct current passing from serosa to mucosa. The difference in transport number at the mucosal barrier and the serosal barrier causes a depletion of NaCl in the lateral intercellular space and, because of osmotic forces, of water. This induces an increase of the electrical resistance of the interspace and therefore of the epithelium.

$t_{Na} \cdot dE_{Na} + t_{Cl} \cdot dE_{Cl}$ with $t_{Na} + t_{Cl} = 1$. In this calculation, the contribution of changes in the apical membrane potential was ignored because the changes are very small [1, 24] and, because of the voltage divider ratio in leaky epithelia, their contribution to the transepithelial potential is even smaller.

From measurements of mucosal dilution potentials [7.6 ± 0.3 mV; $n = 55$, see Results) the average Na transport number of the tight junctions was estimated to $t_{Na} = 0.7$, while in free solution $t_{Na} = 0.4$, as can be calculated from the ionic mobility in free solution.

EFFECT OF PASSAGE OF TRANSEPITHELIAL CURRENT

To study the ion selectivity of the tight junctions we made use of the so-called transport number effect [7, 14] which would decrease the amount of NaCl in the lateral intercellular space when a serosa-positive direct current is passed through the intestinal epithelium (see Fig. 1). This is because most current through the tight junctions is carried from the interspace to the lumen by Na^+ (cation selective tight junctions) while at the serosal side most current is carried from the interspace by Cl^- (in free solution the mobility of Cl^- is larger than the mobility of Na^+). The depletion of NaCl in the lateral intercellular space will lead to increased electrical resistance of this compartment and thus to an increase of the transepithelial resistance. When a larger part of the current at the tight junctional border can be carried by Cl^- , the difference in transport number at the two ends of the paracellular pathway will decrease and the effect of current passage on transepithelial resistance will also decrease.

Current injection from mucosa to serosa will increase the amount of NaCl in the interspace and may induce a decrease of the resistance of the epithelium. Demonstration of the latter change depends on the initial contribution of the lateral intercellular spaces to the total resistance of the paracellular pathway. The change will be hardly detectable when the initial contribution of the resistance of the interspaces to the paracellular resistance is small.

CHEMICALS

The Ringer's composition was (in mM): NaCl 117.5, KCl 5.7, $NaHCO_3$ 25, NaH_2PO_4 1.2, $CaCl_2$ 2.5, $MgSO_4$ 1.2, mannitol (mucosal perfusate only) 27.8, glucose (serosal perfusate only) 27.8. After gas equilibra-

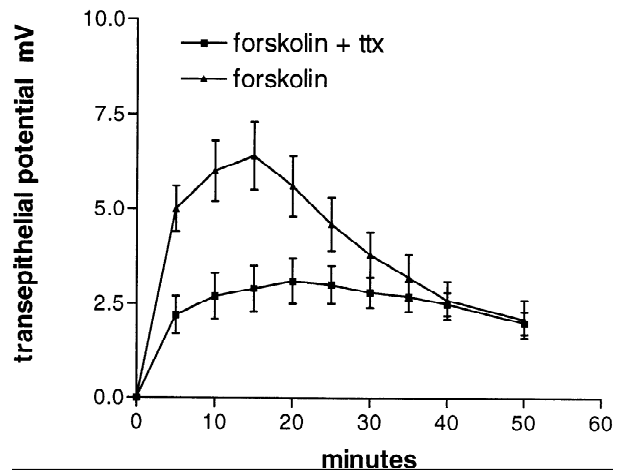

Fig. 2. Transepithelial potential change induced by forskolin (10^{-5} M) added at $t = 0$ to the serosal side in the absence (triangles) and presence (squares) of TTX 10^{-6} M in paired experiments. The potential change reached a maximum at about 10 min and declined to a level similar to TTX ($n = 7$, mean \pm SE). Data points are significantly different till $t = 30$ min ($P < 0.05$, one-tailed Student's t -test).

tion the pH was 7.3 and the osmolarity 320 mOsm. The final concentrations of the secretagogues and inhibitors were: 8-Br-cAMP and dBcAMP 10^{-3} M, forskolin 10^{-5} M, carbachol 10^{-5} M, bumetanide 10^{-4} M, $BaCl_2$ 10^{-3} M, TTX 10^{-6} M, quinidine 10^{-3} M.

Forskolin was dissolved in ethanol, bumetanide and quinidine in methanol, tetrodotoxin (TTX) in Ringer's solution and the other compounds used, in water. The final concentrations of ethanol and methanol were 0.1%. This concentration was without detectable effect. Dilution potentials were induced by replacing 59 mM NaCl by 118 mM mannitol.

All chemicals were obtained from Sigma Chemical (St Louis, MO) except for bumetanide which was a gift of Leo Pharmaceutical Products (Ballerup, Denmark) and radiochemicals which were from Amersham (Amersham International, England).

Statistical significance was tested by paired or unpaired Student's t -test and regression analysis was performed using GraphPad software.

Results

FORSKOLIN- AND CARBACHOL EFFECTS ARE PARTIALLY MEDIATED BY NEURONAL ACTIVATION

Figure 2 shows the change of the transepithelial potential induced by forskolin in the presence and absence of TTX. From the inhibitory effect of TTX on the secretory response, we conclude that the effect of forskolin is partially due to activation of the underlying neuronal tissue. The carbachol-response was also partially sensitive to TTX (Fig. 3) To prevent, as far as possible, the release of unknown transmitters by forskolin or carbachol we applied TTX in most of the further experiments.

CHANGES IN TRANSEPITHELIAL RESISTANCE INDUCED BY FORSKOLIN AND CARBACHOL

Table 1 shows that the increase in transepithelial potential difference induced by either forskolin (row 1) or

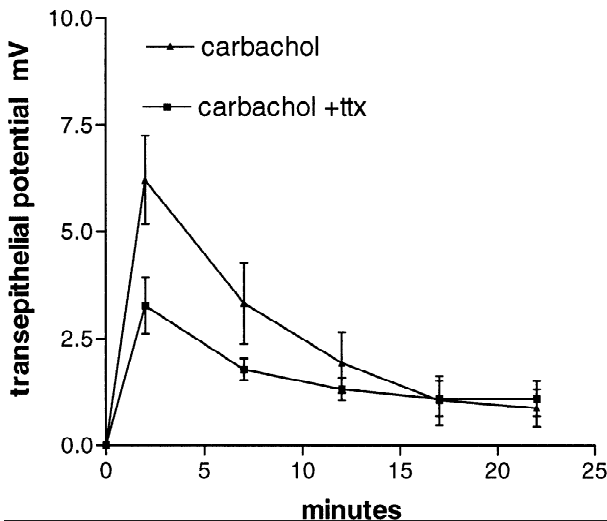

Fig. 3. Transepithelial potential change induced by carbachol (10^{-5} M) added at $t = 0$ to the serosal side in the absence (triangles) and presence (squares) of TTX 10^{-6} M in paired experiments. The potential change reached a maximum at about 2 min and declined to a level similar to TTX ($n = 7$, mean \pm SE). Data points are significantly different till $t = 7$ min ($P < 0.05$, one-tailed Student's t -test).

carbachol (row 3) is accompanied by an increase in transepithelial resistance. To exclude a cAMP-unrelated effect of forskolin, 8-Br-cAMP (1 mM) or dBcAMP (1 mM) was used instead of forskolin. The results were qualitatively not different from the results obtained with forskolin (*not shown*). Therefore, results with cAMP-analogues and forskolin are discussed together. Both, the opening of apical Cl^- and basolateral K^+ channels and a possible increase of Cl^- permeability of the tight junctions would *decrease* the transepithelial resistance. Hence, the observed *increase* is, most probably, due to a collapse of the lateral intercellular spaces [8, 10, 18, 27]. The collapse may result from the net loss of salt and water from the lateral intercellular spaces via the cells to the luminal side. Inhibition of uptake of Cl^- through the basolateral membrane would impede the collapse of the interspace and possibly the resistance-increase induced

by secretagogues. Therefore, bumetanide was applied, which is known to block the NaK2Cl cotransporter in the basolateral membrane and thereby transcellular Cl^- transport [29]. As shown in row 2, the presence of TTX and bumetanide reduced the effect of forskolin on the transepithelial potential change and *reversed* the effect of forskolin on the resistance. The application of bumetanide and TTX had no significant effect on the transepithelial resistance when applied without forskolin (The resistance remained at $99 \pm 1\%$ of its original value). Apparently, the prevention of transcellular Cl^- transport and thereby of a collapse of the lateral spaces unmasks a cAMP induced *decrease* of the transepithelial resistance.

The data in row 4 indicate that the blockers also prevented the carbachol-induced increase of the resistance. However, in this case the presence of bumetanide did not reveal a decrease of the resistance as observed with forskolin.

DISCRIMINATION BETWEEN CELLULAR AND PARACELLULAR EFFECTS

To study whether cAMP can decrease the paracellular resistance, in addition to the decrease of the transepithelial resistance [1], we performed experiments in which the paracellular pathway plays a dominant role.

Diffusion Potentials Induced by Serosal Dilution of NaCl

It has been shown earlier in our laboratory that isosmotic replacement of NaCl in the serosal compartment of isolated rat ileum caused a smaller (serosa positive) potential change when dBcAMP or forskolin was present [16]. When only Na^+ in the serosal compartment was partially replaced by N-methylglucamine (NMG) the presence or absence of forskolin had no significant effect on the (serosa positive) biionic potential. In contrast the (serosa negative) biionic potential was larger in the presence of one of these secretagogues when only serosal Cl^- was partially replaced by gluconate. These observations

Table 1. Effect of forskolin and carbachol on transepithelial resistance and potential

	$R_0 \Omega \cdot \text{cm}^2$	$R_t \Omega \cdot \text{cm}^2$	$\Delta R \Omega \cdot \text{cm}^2$	$\Delta\psi, (\text{max}) \text{mV}$	n
1) Fskln	21.2 ± 0.9	24.2 ± 1.0	$+3.0 \pm 0.9$	6.2 ± 0.3	44
2) Fskln + bum + TTX	23.8 ± 1.5	19.8 ± 1.2	-4.0 ± 0.3	1.5 ± 0.2	19
3) Carbachol	18.2 ± 1.5	24.0 ± 1.9	$+5.8 \pm 0.8$	7.4 ± 0.6	12
4) Carbachol + bum + TTX	21.6 ± 1.5	21.1 ± 1.5	-0.5 ± 0.5	1.0 ± 0.1	17

The changes in resistance and potential are all significantly different from 0 (Students t test, $P < 0.001$) except for the change of resistance in row 4. Abbreviations: fskln = forskolin, bum = bumetanide, TTX = tetrodotoxin, R_0 = initial resistance, R_t = resistance at 10 min after forskolin or 7 min after carbachol. $\Delta\psi, (\text{max})$ were taken at the peak of the potential change. Bumetanide and TTX were added 10 min before the secretagogue.

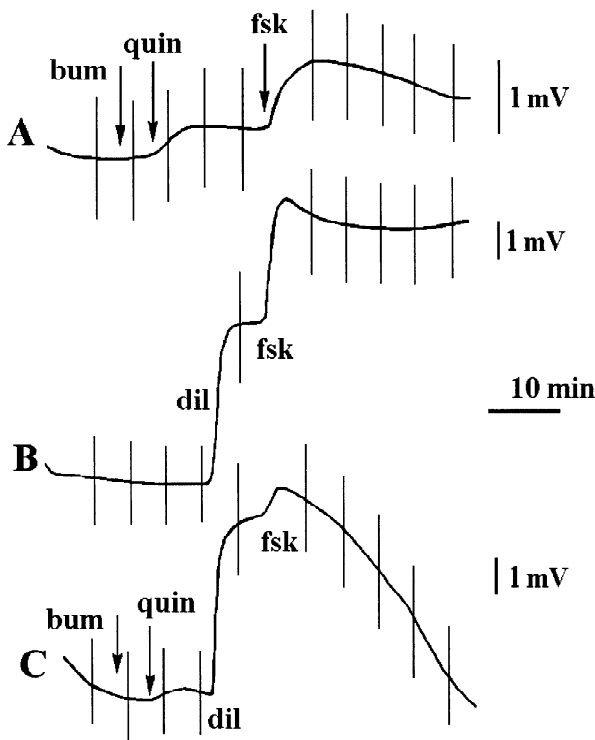

Fig. 4. Trans epithelial potential changes induced by forskolin after (A) serosal application of bumetanide and quinidine, (B) serosal dilution of NaCl, (C) serosal application of bumetanide and quinidine and serosal dilution of NaCl. The tracings are examples from a set of 3 experiments each. Voltage deflections induced by bipolar current pulses of + and $-10 \mu\text{A}$. Potential change caused by serosal NaCl dilution have to be corrected for the diffusion potential across the salt bridge (Ringer's agar) in the serosal compartment (-1.9 mV). TTX, 10^{-6} M , was present in the serosal bath from the start of the experiments.

can be explained by one or more of the following possibilities: (i) an increased permeability for Cl^- of the tight junctions, (ii) increased influence of the lateral intercellular space because of its collapse caused by secretion induced by cAMP or (iii) reduced secretory current due to the lower Cl^- concentration in the serosal bath and therefore lower substrate concentration for the NaK2Cl cotransporter.

To test these possibilities we compared the effect of forskolin during serosal dilution of NaCl in the presence and in the absence of bumetanide and quinidine, with TTX present from the beginning of the experiment. (Quinidine blocks basolateral K^+ channels [17] thereby preventing electrogenic efflux of Cl^- through the apical membrane, and also making the basolateral membrane less responsive to ion changes in the serosal bath.). As shown in Fig. 4a the presence of the two blockers strongly suppressed the electrogenic Cl^- transport ($n = 3$: $\Delta\psi_t = 0.8, 1.1, 1.0 \text{ mV}$ compared with 6.2 mV without blockers, see Table 1). Therefore, dilution of the serosal NaCl concentration will be of no influence on

forskolin-induced transepithelial current because it is already inhibited so that explanations based on possibility (iii) are unlikely. Moreover, the collapse of the lateral intercellular spaces will not occur (see Table 1) and therefore one can exclude that forskolin increased the influence of the lateral intercellular space (ii) under this condition.

Figure 4b shows that, without blockers, the transepithelial potential increased in response to the forskolin application after serosal dilution of NaCl ($n = 3$: $\Delta\psi_t = 5.0, 3.6, 4.0 \text{ mV}$). Figure 4c shows this response in the presence of the blockers ($n = 3$: $\Delta\psi_t = 0.8, 0.2, 1.2 \text{ mV}$). Comparison with Fig. 4a shows that the small increase of the potential difference is very short lasting and in comparison with Fig. 4b the presence of the secretagogue induces a decrease of the transepithelial potential, indicating that forskolin reduced the cation selectivity of the epithelium. Changes of ion selectivity from changes in the basolateral membrane or from collapse of the lateral intercellular space can be ruled out. Hence, the experiment shown in Fig. 4c in combination with the published insensitivity to changes in Na^+ concentration [16] indicates that forskolin reduced the ion selectivity of the tight junctions by increasing its Cl^- permeability.

Transport Number Effects in the Absence of Secretagogues

Like in other leaky epithelia, current passage increased the transepithelial resistance when current was passed from serosa to mucosa ($I_{s \rightarrow m}$) and decreased the resistance when current was passed from mucosa to serosa in rat ileum (Fig. 5).

The small decrease of transepithelial resistance (15%) due to mucosa-to-serosa current indicates that the contribution of the lateral spaces to the paracellular resistance was small, and thus normally, the tight junctions make up the principal barrier to paracellular ion movements.

To verify that the serosa-to-mucosa current collapsed the interspace, the response of the transepithelial potential to apical application of glucose during serosa-to-mucosa current injection was compared with its normal response. This experiment is based on the following consideration. Glucose increases the transcellular current from mucosa to serosa through villus enterocytes which flows back through the paracellular pathway and thereby generates the glucose evoked potential difference (GEP). A larger resistance of the interspace would increase the GEP. The prediction is that a GEP during serosa-to-mucosa current passage will be larger than under control conditions while the glucose-evoked transepithelial current will not be affected. In four parallel experiments, GEP was $1.3 \pm 0.1 \text{ mV}$ under control conditions. The transepithelial resistance was $23 \pm 3 \Omega \cdot \text{cm}^2$

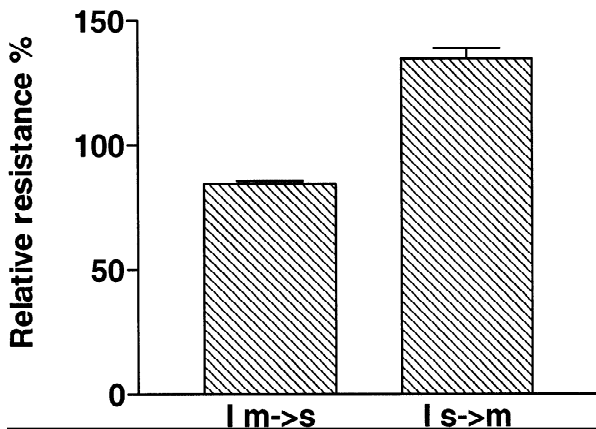

Fig. 5. The histogram shows the mean transepithelial resistance as a percentage of the resistance before current injection of 100 μA . Passage of the current from mucosa to serosa induced a decrease of the resistance while direct current from serosa to mucosa increased the resistance. (Initial resistance $21 \pm 1 \text{ ohm} \cdot \text{cm}^2$; mean and SE of 17 experiments.)

and the glucose evoked current was calculated from Ohm's law as $56 \pm 7 \mu\text{A}/\text{cm}^2$. GEP during $I_{s \rightarrow m}$ of 150 μA was $2.3 \pm 0.2 \text{ mV}$, transepithelial resistance $38 \pm 2 \Omega \cdot \text{cm}^2$ and the glucose induced current $61 \pm 7 \mu\text{A}/\text{cm}^2$. Thus, the glucose evoked potential was significantly larger during $I_{s \rightarrow m}$ ($P < 0.001$) while the current was not different, indicating that $I_{s \rightarrow m}$ increased the resistance of the paracellular shunt pathway.

Effect of Forskolin and Carbachol on Transport Number Effects

If cAMP can increase the Cl^- conductance in tight junctions, the difference between t_{Na} in the tight junctions (0.7, see Materials and Methods) and that in free solution (0.4, see Materials and Methods) would become smaller and thus the changes in the resistance of the paracellular shunt pathway induced by current passages would be decreased in the presence of forskolin.

This was tested by passing serosa-to-mucosa current in the absence and presence of forskolin. Experiments were done in the presence of TTX, bumetanide and Ba^{2+} (see footnote¹). Figure 6 shows the time course of the

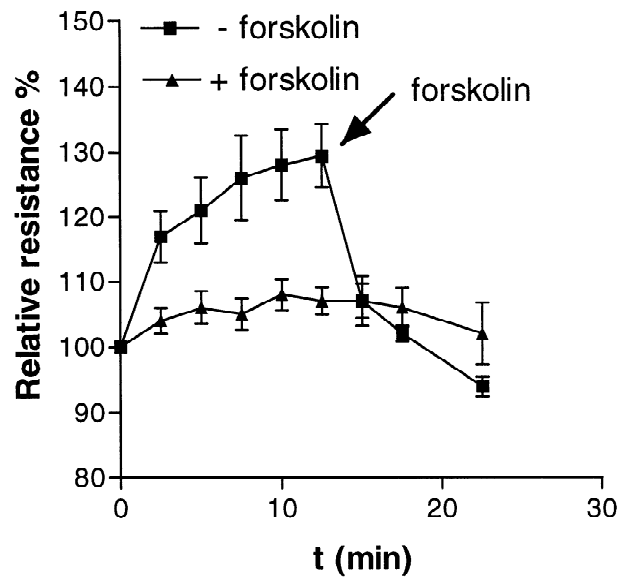

Fig. 6. Time course of the change of the transepithelial resistance induced by direct current of 200 μA from serosa to mucosa in the presence of TTX, bumetanide and BaCl_2 . The lower curve is in the presence of forskolin, added at 10 min before start of current injection. At the arrow forskolin was added to the other sheets. (mean \pm SE of 5 experiments).

change in resistance due to direct current passage from serosa to mucosa. The serosa-to-mucosa current in the absence of forskolin led to a resistance increase as shown in Fig. 5. Apparently, the presence of the blockers had no effect on this phenomenon. The presence of forskolin prevented the increase of the resistance, and application of forskolin at $t = 12.5 \text{ min}$ after starting the current passage, immediately decreased the resistance. Application of TTX and bumetanide during current passage was without effect on the resistance (*not shown*). The suppression by forskolin adds to the evidence for a reduction of the cation selectivity of the tight junctions by cAMP.

The reduction in cation selectivity of the tight junctions combined with the cAMP dependent decrease of the transepithelial resistance in the presence of bumetanide (Table 1), indicate that in rat ileum, a rise in intracellular cAMP can increase the Cl^- conductance in tight junctions.

Figure 7 shows a comparison between the effects of forskolin and carbachol on the change of the resistance due to serosa-to-mucosa current passage. Carbachol could not prevent the current-induced increase in trans-

¹ Direct currents passed through the epithelium, will predominantly take the paracellular route as this shunt comprises about 95% of the conductance of rat ileum (24). However, in the presence of forskolin the cellular pathway increases its conductance. Current from serosa to mucosa may induce an influx of K^+ through the basolateral membranes and of Cl^- through the apical membranes, thus leading to an increase of cellular KCl and cell volume and presumably, a decrease of the diameter of the lateral intercellular space, possibly leading to an increase in transepithelial resistance. This hypothetical effect would be minimized

by blocking the basolateral K^+ conductance with Ba^{2+} . In comparing experiments with and without Ba^{2+} , however, we have not found differences. The maximal relative resistance under control conditions after 100 μA serosa-to-mucosa current injection was $135 \pm 5\%$ and with Ba^{2+} $127 \pm 5\%$ ($n = 8$).

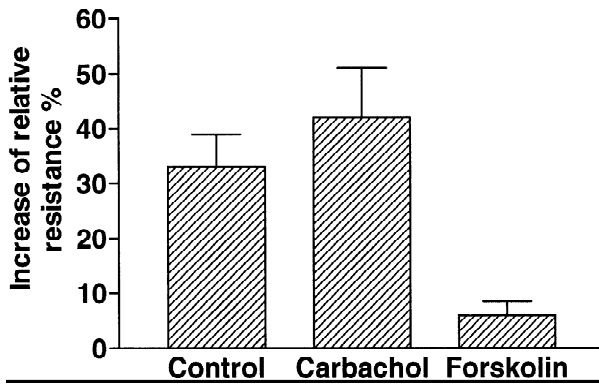

Fig. 7. Comparison of the increase of the relative resistance (% from initial resistance) induced by serosa-to-mucosa direct current with carbachol (middle) or forskolin (right). Carbachol could not prevent the transport number effect. (100 μ A in control and carbachol experiments, 200 μ A in the presence of forskolin mean \pm SE of 8 experiments).

epithelial resistance. Thus, it appears that the increase of the Cl^- conductance in tight junctions is a cAMP-related phenomenon.

Effect of cAMP on Ion Fluxes

If cAMP can increase the Cl^- permeability of the tight junctions, one would expect that even in the presence of bumetanide the fluxes from serosa to mucosa and from mucosa to serosa should increase. Table 2 shows that in the presence of bumetanide cAMP can still increase the serosa-to-mucosa but also the mucosa-to-serosa flux. Without bumetanide, the addition of cAMP increased the serosa-to-mucosa flux and decreased the mucosa-to-serosa flux.

To test for the possibility that the paracellular sodium permeability was changed, the serosa-to-mucosa Na^+ flux was measured in another set of experiments. The control flux in the presence of bumetanide ($19.1 \pm 1.3 \mu\text{mol}/\text{cm}^2 \cdot \text{hr}$, $n = 12$) was not different from the flux in the presence of 8-Br-cAMP plus bumetanide ($21.1 \pm 1.0, \mu\text{mol}/\text{cm}^2 \cdot \text{hr}$, $n = 12$).

THE EFFECT OF CAMP ON TRANSEPITHELIAL RESISTANCE VARIES BETWEEN PREPARATIONS

Table 1, row 1 shows that the average effect of forskolin on the transepithelial resistance is an increase. However, when considering the individual experiments, it appeared that, depending on the initial resistance, the addition of forskolin or 8-Br-AMP either increased or decreased the conductance. (The application of forskolin or 8-Br-cAMP in the presence of bumetanide always increased the conductance.) Figure 8 shows the relation between the forskolin and cAMP induced change in transepithelial conductance and the initial resistance. The slope of

Table 2. Cl^- fluxes and the effects of dBcAMP and bumetanide

	J m \rightarrow s $\mu\text{mol}/\text{cm}^2 \cdot \text{hr}$ (n)	J s \rightarrow m $\mu\text{mol}/\text{cm}^2 \cdot \text{hr}$
Control	18.0 ± 0.9 (19)	13.9 ± 0.9 (21)
$\Delta\text{J}(\text{dB-cAMP})$	-1.8 ± 0.5 (12)	3.1 ± 1.0 (12)
$\Delta\text{J}(\text{bum} + \text{dB-cAMP})$	1.5 ± 0.4 (7)	1.5 ± 0.5 (9)

Control fluxes were calculated from samples taken at $t = 30$ and $t = 40$ min after start of experiment. dBcAMP or dBcAMP + bumetanide were added thereafter. Changes induced by these additions were calculated from samples taken at $t = 50$ and $t = 60$ min and compared to their respective control values.

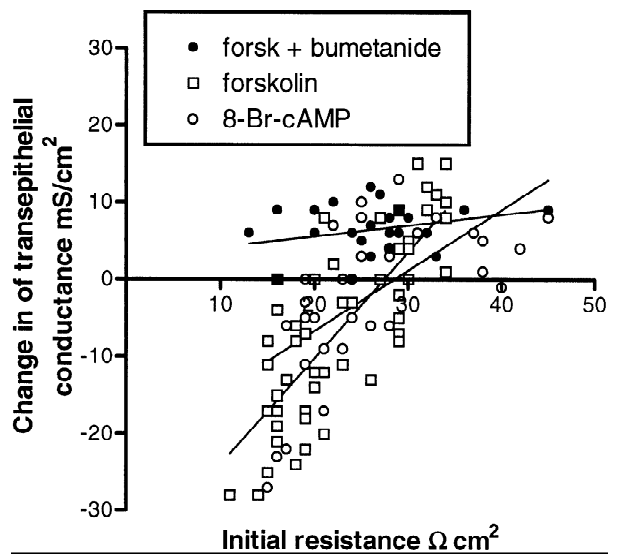

Fig. 8. Change of the transepithelial conductance (mS/cm^2) induced by 8-Br-cAMP or forskolin in the absence or presence of bumetanide as a function of the initial resistance of the intestinal sheet. The slope of the regression lines of data without bumetanide (forskolin, open squares: 1.37 ± 0.14 , 8-Br-cAMP, open circles: 0.78 ± 0.15) differ significantly from zero ($P < 0.001$) and significantly from the slope of the regression line of data with bumetanide (0.14 ± 0.09) which is not different from zero. Note that in the presence of bumetanide (filled circles) the conductance always increases while without bumetanide (open symbols) the chance of an increase is much larger with larger initial resistances.

the regression line of data in the absence of bumetanide differs significantly from zero, whereas in the presence of bumetanide the deviation of the slope from zero is not significant. This suggests that the cAMP-induced collapse of the lateral spaces correlates with the initial resistance. We will argue in the discussion that the variation in behavior of the preparations and initial resistance may be due to differences in the Na^+ permeability of the tight junctions. This is corroborated by the observed ion selectivity of the tight junctions as determined from the mucosal dilution potentials. Figure 9 shows the relation between the dilution potential (mean $7.6 \pm 0.3 \text{ mV}$, $n = 55$) and the initial resistance (mean $22.5 \pm 0.8 \text{ ohm} \cdot \text{cm}^2$,

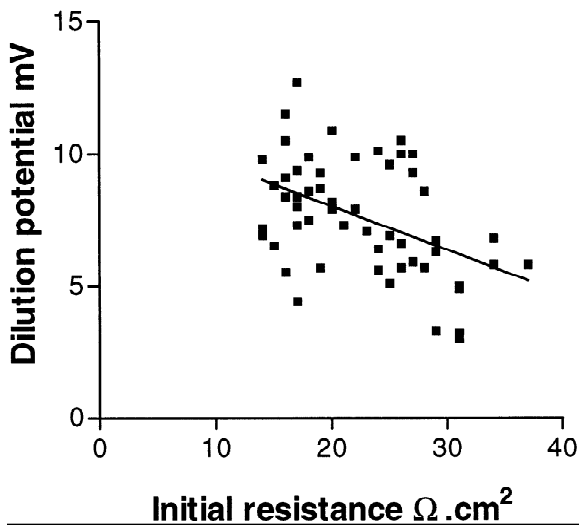

Fig. 9. Relation between the change of diffusion potential induced by replacing 59 mM NaCl in the mucosal compartment with 118 mM mannitol (Dilution potential) and the initial resistance of the intestinal sheets. The slope of the line differs significantly from zero ($P < 0.005$).

$n = 55$). The results show that low resistances are associated with large dilution potentials i.e., larger cation selectivity and vice versa. From the initial resistance and the dilution potentials the conductance of the tight junction for Na^+ ($g_{\text{Na,tj}}$) and Cl^- ($g_{\text{Cl,tj}}$) can be estimated. Figure 10 shows $g_{\text{Na,tj}}$ and $g_{\text{Cl,tj}}$ as a function of the initial resistance. Apparently, the variation in transepithelial resistance results primarily from endogenous differences in Na^+ permeability of the tight junctions.

Similarly, analysis of the individual data of transport number effects upon serosa-to-mucosa current injection (Fig. 11) also reveals a correlation with the initial resistance; the lower resistances (larger cation selectivity) showing the larger transport number effects.

Discussion

THE MODULATION OF THE Cl^- CONDUCTANCE OF THE TIGHT JUNCTION

The principal findings in this study are that cAMP in rat ileum reduced the transepithelial potential evoked by serosal dilution of NaCl and prevented the increase of the resistance induced by passage of direct current from serosa to mucosa. Both findings can be interpreted as evidence that cAMP decreased the cation selectivity of the tight junctions. This interpretation is based on the assumption that (i) the properties of the leak pathway predominate in the serosal dilution potential and that (ii) the increase of the transepithelial resistance by serosa-to-mucosa current is due to the collapse of the lateral in-

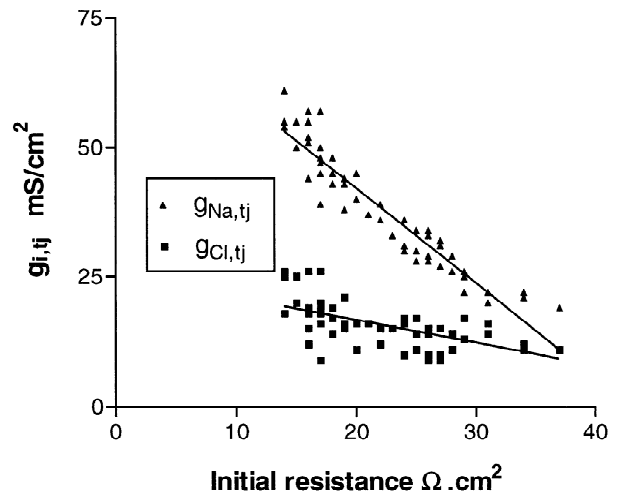

Fig. 10. Conductance of tight junctions (mS/cm^2) for Na^+ and for Cl^- vs. initial resistance of the epithelium. Slopes of regression lines are significantly different ($P < 0.001$). Cation selectivity decreased with resistance. For estimation of ion conductances see methods.

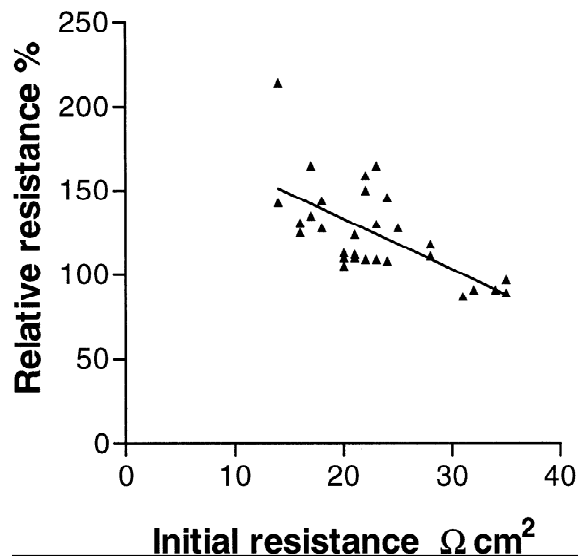

Fig. 11. Individual data showing the increase of the relative resistance caused by serosa-to-mucosa current passage. The negative slope of the regression line is significantly different from zero ($P < 0.001$). This suggests that transport number effects are smaller with larger initial resistance of the epithelium. (Data from experiments with $100 \mu\text{A}$ serosa-to-mucosa current injection.)

tercellular space by the transport number effect. Under the conditions that were used to measure the serosal dilution potential, i.e., presence of K^+ channel blocker plus bumetanide to prevent uptake of Cl^- and thereby the transcellular Cl^- transport, the first assumption seems valid. The second assumption was confirmed by the larger GEP during serosa to mucosa current passage. The observed increase of the GEP indicate that a path-

way parallel to the villus epithelial cells had increased its resistance. In a leaky epithelium like rat ileum this indicates a resistance increase of the paracellular pathway by a collapse of the interspaces. This is because the differing effect of serosa-to-mucosa current and the mucosa-to-serosa current makes it inconceivable that the resistance increase is in tight junctions. (It should be pointed out here, that in rat ileum, under the conditions of these experiments, glucose does not increase the transepithelial conductance (P.B. Bijlsma, *unpublished observations*). This increase has been found in other intestinal preparations with differing experimental conditions [25]. Even if glucose can modulate the tight junctions in a way that could not be detected in our experiments it would not affect the conclusion that during current passage from serosa to mucosa the paracellular resistance is higher.) Therefore, it is concluded that both types of experimental conditions, i.e., serosal dilution potentials and transport number effects, which amplify the visibility of changes in ion selective properties of the tight junctions, indicate that cAMP can reduce the cation selectivity of the tight junctions.

The cation selectivity of the tight junctions may be reduced by a decrease of the Na^+ conductance and/or by an increase of the Cl^- conductance. From the results of the serosa-to-mucosa Na^+ flux measurements we consider the first possibility less likely because the diffusional flux in the presence of bumetanide appears to be unaffected by cAMP. This observation corroborates earlier results in rat small intestine [17] where it has been shown that the diffusional flux of Na^+ was not affected by secretagogues. An increase of the conductance in the tight junction for Cl^- , in combination with the decrease of the cellular resistance because of activation of the apical Cl^- channels [1, 30] would lead one to expect to see a decrease of the transepithelial resistance. However, secretion usually goes together with an increased transepithelial resistance. Apparently, this is not because of a decrease of the Na^+ conductance in the tight junctions but is caused by the decrease of the diameter of the lateral intercellular spaces [8, 10, 18, 27]. We propose that the interspace collapses because of the depletion of NaCl caused by a faster uptake through the basolateral membrane than diffusion of NaCl into the interspace, as discussed in the next paragraph. By decreasing the uptake of NaCl through the basolateral membrane with bumetanide the resistance-increase could indeed be reversed to a decrease.

From the combination of the results it is concluded that the most plausible explanation for the forskolin-induced decrease in transepithelial resistance, as observed in the presence of bumetanide, is an increased conductance for Cl^- in the tight junctions as well as in the apical membranes.

This correlates with the observation in filter-grown

monolayers of T_{84} cells, a mammalian intestinal cell line, where it has been found that VIP, which activates adenylate cyclase, increased not only the secretory serosa-to-mucosa flux but also the Cl^- flux from mucosa to serosa, suggesting an increase of the diffusional, paracellular pathway in addition to the transcellular Cl^- secretion [9]. In HT-29cl.19A cells (another model intestinal cell line), the conductance of the transcellular pathway can reach its maximum while the transepithelial conductance continues to increase. This suggests the modulation of the paracellular conductance with a larger time constant than the change in conductance of the apical membrane [1]. Thus, the cAMP mediated increase of the Cl^- conductance in tight junctions seems to occur not only in fish intestine but also in rat ileum and human cell lines.

The results demonstrate an interesting difference between the action of forskolin and carbachol. Carbachol is thought to activate multiple signaling effectors including Ca^{2+} and Protein kinase C [12] leading to an increased conductance of apical Cl^- channels in HT29cl.19A cells [2] and an increase of the NaCl secretion in rat ileum like with cAMP [17]. However, carbachol did not change the ion selectivity of the tight junctions and did not decrease the transepithelial resistance in the presence of bumetanide. Thus, the modulation of ion selectivity of the tight junctions appears to be specific for cAMP. This is like in fish intestine, where it has been found that carbachol or the increase of cellular Ca^{2+} by ionomycin or activation of PKC by phorbol esters could not mimic the effect of cAMP on the tight junctions [3].

VARIATION IN BEHAVIOR OF INDIVIDUAL TISSUE PREPARATIONS

To explain the correlation between the cAMP-induced change in conductance and the initial resistance of the tissue in the absence of bumetanide (Fig. 8), we will first illustrate how the collapse of the lateral spaces may result from transcellular Cl^- secretion. Figure 12 shows a simplified scheme of the ion movements during Cl^- secretion in an open-circuited preparation. The combined result of the NaK2Cl cotransporter, the NaKpump and the K^+ permeability in the basolateral membrane is the net transport of Cl^- ions from the lateral spaces across the basolateral membrane and through the apical membrane into the lumen. This is equivalent to a transcellular mucosa-to-serosa direct current. In an open-circuited epithelium, this current must be compensated by an equal serosa-to-mucosa current, i.e., from the lateral spaces through the tight junctions to the lumen. The ion selectivity of the tight junctions determines the proportion of this current carried by Na^+ ions moving from the spaces to the lumen, or by Cl^- ions in the opposite direction. In other words, the ion selectivity of the tight junctions

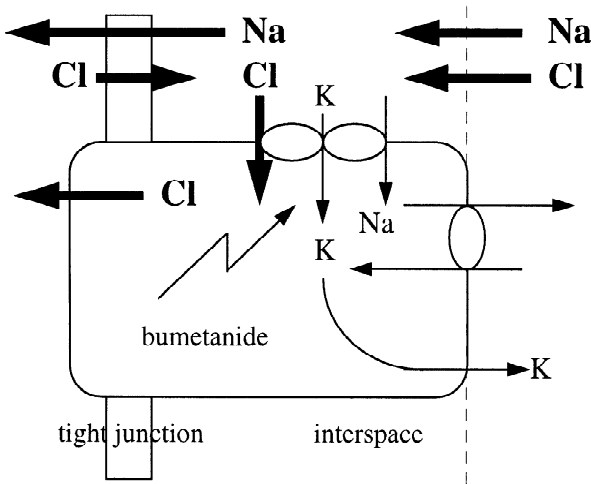

Fig. 12. Schematic representation of the ion movements during Cl^- secretion under open-circuit condition. For clarity NaCl fluxes, discussed in the text are shown in bold.

determines the (partial) recycling of Cl^- ions, and thus the required inflow of NaCl from the serosal solution. When the supply of NaCl by diffusion or fluid movement is insufficient, the spaces will collapse. Therefore, the strength of the secretory transcellular current and the ion-selective properties of the tight junctions determine to a large extent whether transcellular Cl^- secretion will be accompanied by a partial collapse of the lateral spaces and thus by a decrease of the transepithelial conductance. In view of this mechanism, the observation shown in Fig. 8, namely that application of cAMP to specimen with the lower initial resistances decreased the transepithelial conductance, suggests that the Na^+ conductance and hence the cation selectivity of the tight junctions is still too high to allow sufficient Cl^- recycling—despite the increase of the Cl^- conductance in tight junctions—and to prevent a collapse of the lateral spaces. Further evidence for the role of the Na^+ conductance of the tight junctions in the collapse of the interspace can be drawn from Holman et al. [18]. These authors have shown that theophylline induces a collapse of the intercellular space in rabbit ileum. However, no collapse was observed when the Na^+ permeability in the tight junctions was reduced by 2,4,6-triaminopyrimidine [23].

The variation in dilution potentials (the larger dilution potentials observed in the tissues with the lower initial resistance) and the transport number effect (the larger effect in tissues with the lower initial resistance) likewise indicates that the transport number for Na^+ in the tight junctions is larger in tissues with the lower initial resistances.

Thus, the three findings in tissues with lower initial transepithelial resistances: (i) that they have larger dilution potentials (ii) that they show an increase of the resistance when forskolin was applied and (iii) that they

show a larger increase of the resistance upon serosa-to-mucosa current injection, appear to be based on the larger conductance of the tight junctions for Na^+ .

The regulation of the ion selectivity of the tight junctions may be of physiological relevance to modulate salt and water transport through the paracellular pathway [15]. It may be of relevance to prevent a collapse of the lateral intercellular spaces when under open-circuit conditions like during sugar or amino acid uptake or during secretory activity in vivo a transepithelial current is flowing from serosa to mucosa, predominantly through the crypts [22] because of their lower paracellular resistance.

In conclusion, the results show evidence that the ion selectivity of tight junctions in rat ileum is under control of a cAMP-related mechanism that can increase the Cl^- conductance in that structure. In contrast, carbachol could not increase the Cl^- conductance in the tight junctions. (In a parallel study [6a] we report that carbachol, but not forskolin, can induce an increased uptake of intact protein from the mucosal side and an increased transepithelial transport of nonelectrolytes and of intact protein by, primarily, the paracellular route.) In addition, the variation in Na^+ conductance of the tight junctions may be evidence for the presence of an independent mechanism for the regulation of the Na^+ conductance.

We thank K. Dekker and Dr. W.P. Oosterhuis for their participation in the flux experiments.

References

- Bajnath, R.B., Augeron, C., Laboisse, C.L., Bijman, J., de Jonge, H.R., Groot, J.A. 1991. Electrophysiological studies of forskolin-induced changes in ion transport in the human colon carcinoma cell line HT-29 cl.19A—lack of evidence for a cAMP-activated basolateral K^+ conductance. *J. Membrane Biol.* **122**:239–250
- Bajnath, R.B., Dekker, K., Vaandrager, A.B., De Jonge, H.R., Groot, J.A. 1992. Biphasic increase of apical Cl^- conductance by muscarinic stimulation of HT-29cl.19A human colon carcinoma cell line—evidence for activation of different Cl^- conductances by carbachol and forskolin. *J. Membrane Biol.* **127**:81–94
- Bakker, R., Dekker, K., De Jonge, H.R., Groot, J.A. 1993. VIP, serotonin, and epinephrine modulate the ion selectivity of tight junctions of goldfish intestine. *Am. J. Physiol.* **264**:R362–R368
- Bakker, R., Groot, J.A. 1984. cAMP-mediated effects of ouabain and theophylline on paracellular ion selectivity. *Am. J. Physiol.* **246**:G213–G217
- Bakker, R., Groot, J.A. 1989. Further evidence for the regulation of the tight junction ion selectivity by cAMP in goldfish intestinal mucosa. *J. Membrane Biol.* **111**:25–35
- Barry, P.H., Diamond, J.M., Wright, E.M. 1971. The mechanism of cation permeation in rabbit gallbladder. *J. Membrane Biol.* **4**:358–394
- Bijlsma, P.B., Kiliaan, A.J., Scholten, G., Heyman, M., Groot, J.A., Taminiu, J.M. 1996. Carbachol, but not forskolin, increases mucosal-to-serosal transport of intact protein in rat ileum in vitro. *Am. J. Physiol.* **271**:G147–G155
- Bindsløv, N., Tormey, J.M.D., Wright, E.M. 1974. The effects of electrical and osmotic gradients on lateral intercellular spaces and

- membrane conductance in a low resistance epithelium. *J. Membrane Biol.* **19**:357–380
8. Corbett, C.L., Isaacs, P.E.T., Hawker, P.C., Turnberg, L.A. 1977. Theophylline-induced changes in ion transport and conductance in human small intestinal mucosa. *Nature* **267**:714–717
 9. Dharmasathaphorn, K., Mandel, K.G., Masui, H., McRoberts, J.A. 1985. Vasoactive intestinal polypeptide-induced chloride secretion by a colonic epithelial cell line: Direct participation of a basolaterally localized Na,K,Cl cotransport system. *J. Clin. Invest.* **75**:462–471
 10. DiBona, D.R., Chen, I.C., Sharp, G.W.G. 1974. A study of intercellular spaces in the rabbit jejunum during active volume expansion and after treatment with cholera toxin. *J. Clin. Invest.* **53**:1300–1307
 11. Duffey, M.E., Hainau, S., Ho, S., Bentzel, C. 1981. Regulation of epithelial tight junction permeability by cAMP. *Nature* **294**:451–453
 12. Felder, C.C. 1995. Muscarinic acetylcholine receptors: signal transduction through multiple effectors. *FASEB J.* **9**:619–625
 13. Frizzell, R.A., Schultz, S.G. 1972. Ionic conductances of extracellular shunt pathway in rabbit ileum. *J. Gen. Physiol.* **59**:318–346
 14. Frömter, E. 1972. The route of passive ion movement through the epithelium of *Necturus* gallbladder. *J. Membrane Biol.* **8**:259–301
 15. Groot, J.A., Bakker, R. 1988. NaCl transport in the Vertebrate Intestine. In: *Advances in Comparative and Environmental physiology*. R. Greger, editor, pp. 103–152. Springer, Berlin
 16. Groot, J.A., Bakker, R., Dekker, K., Oosterhuis, W.P. 1986. Modulation of transepithelial ion permeability by neurohumoral agents: comparison of fish and rat intestine. In: *Ion Gradient Coupled Transport*. F. Alvarado and C.H. van Os, editors. pp. 411–414. Elsevier, Amsterdam
 17. Hardcastle, J., Hardcastle, P.T., Noble, J.M. 1984. The involvement of calcium in the intestinal response to secretagogues in the rat. *J. Physiol.* **355**: 465–478
 18. Holman, G.D., Naftalin, R.J., Simmons, N.L., Walker, M. 1979. Electrophysiological and electron-microscopical correlations with fluid and electrolyte secretion in rabbit ileum. *J. Physiol.* **290**:367–386
 19. Kottra, G., Haase, W., Frömter, E. 1993. Tight-junction tightness of *Necturus* gall bladder epithelium is not regulated by cAMP or intracellular Ca²⁺. I. Microscopic and general electrophysiological observations. *Pfluegers Arch.-Eur. J. Physiol.* **425**:528–534
 20. Krasny, E.J., Frizzell, R.A. 1984. Intestinal ion transport in marine teleosts. In: *Chloride Transport Coupling in Biological Membranes and Epithelia*. G.A. Gerencser, editor. pp. 205–218. Elsevier Science Publishers, Amsterdam
 21. Madara, J.L., Barenberg, D., Carlson, S. 1986. Effects of cytochalasin D on occluding junctions of intestinal absorptive cells: further evidence that the cytoskeleton may influence paracellular permeability and junctional charge selectivity. *J. Cell. Biol.* **97**:125–136
 22. Marcial, M.A., Carlson, S.L., Madara, J.L. 1984. Partitioning of paracellular conductance along the crypt-villus axis: A hypothesis based on structural analysis with detailed consideration of tight junction structure function relationships. *J. Membrane Biol.* **80**:59–70
 23. Moreno, J.H. 1975. Blockage of gallbladder tight junction cation-selective channels by 2,4,6-tiaminopyrimidinium (TAP). *J. Gen. Physiol.* **66**:97–115
 24. Okada, Y., Irimajiri, A., Inouye, A. 1977. Electrical properties and active solute transport in rat small intestine. II. Conductive properties of transepithelial routes. *J. Membrane Biol.* **31**: 221–232
 25. Pappenheimer, J.R. 1987. Physiological regulation of transepithelial impedance in the intestinal mucosa of rats and hamsters. *J. Membrane Biol.* **100**:137–148
 26. Petersen, K.U., Reuss, L. 1983. Cyclic AMP-induced chloride permeability in the apical membrane of *Necturus* gallbladder epithelium. *J. Gen. Physiol.* **81**:705–729
 27. Powell, D.W. 1974. Intestinal conductance and permselectivity changes with theophylline and cholera toxin. *Am. J. Physiol.* **227**: 1436–1443
 28. Rao, M.C., Nash, M.T., Field, M. 1984. Differing effects of cGMP and cAMP on ion transport across flounder intestine. *Am. J. Physiol.* **246**: C167–C171
 29. Scheffler, A., Heintze, K., Mussler, K. 1984. Bumetanide as an inhibitor of the PGE₁- and theophylline-stimulated electrogenic chloride secretion in rabbit colon *in vitro*. In: *Intestinal Absorption and Secretion*. E. Skadhauge and K. Heintze, editors. pp. 335–342. MTP Press, Lancaster
 30. Stewart, C.P., Turnberg, L.A. 1989. A microelectrode study of responses to secretagogues by epithelial cells on villus and crypt of rat small intestine. *Am. J. Physiol.* **257**:G334–G343